

INSTALLATION ADJUSTMENT SERVICE THERMOSTATIC WATER MIXING VALVE TM-200 (NEW STYLE) TMS-200 (VALVE ONLY)

IMPORTANT! This Bulletin covers valves built after June 2001, starting with serial number TM2000257 or TMX2000001 and above. See Bulletin G-2D or G-2C for valves built before this date. Provide valve serial numbers (stamped on cover of valve) when ordering parts!

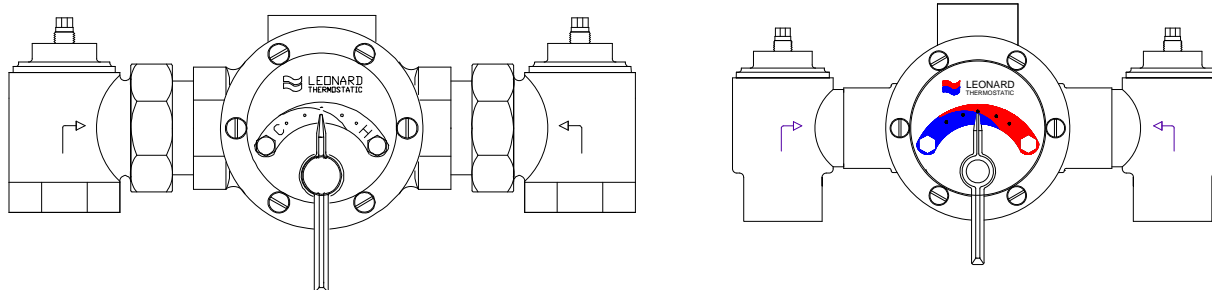

WARNING: This product can expose you to chemicals including lead, which is known to the State of California to cause cancer. For more information, go to www.P65Warnings.Ca.gov



INSTALLATION

1. Valve should be installed where it can easily be cleaned, adjusted or repaired.
2. The inlets are clearly marked on the valve body casting. Connect the hot water (or steam for TMS valves) into the inlet marked "HOT" and cold water into the inlet marked "COLD". These are not to be confused with the "C-H" markings on the front cover.
3. Union angle checkstops furnished must be installed on both supply lines as shown above.
4. A shutoff valve must be installed on the outlet pipe. Type TM valves do not have a built-in shutoff.
5. Use solder or pipe cement sparingly. Supply pipes should be flushed before the valve is connected. Flush outlet pipe and valve as soon as it is connected.
6. Refer to page 3 of this bulletin for correct Setup Instructions.

Maximum Operating Pressure 125PSI (860 KPA) for Hot and Cold Water.

!!! CAUTION !!!

All thermostatic water mixing valves have limitations. They will not provide the desired accuracy outside of their flow capacity range. Consult the capacity chart on page 6. Minimum flow must be no less than as shown.

REMEMBER! THIS IS A CONTROL SYSTEM WHICH MUST BE CLEANED AND MAINTAINED ON A REGULAR BASIS (SEE MAINTENANCE GUIDE AND RECORD MGR-1000).

1360 Elmwood Avenue, Cranston, RI 02910 USA
Phone: 401.461.1200 Fax: 401.941.5310
Email: info@leonardvalve.com
Web Site: <http://www.leonardvalve.com>

ADJUSTMENT AND SERVICE

Leonard Type TM Thermostatic Water Mixing Valves are simple in design and may be easily cleaned, adjusted and repaired. If the installation is accessible, servicing may be completed without disconnecting the valves.

NOTE: Thermostatic Water Mixing Valves, which must be regularly maintained to provide best performance. Frequency of cleaning depends on quality of local water conditions and usage. See Maintenance Guide and Record MGR-1000.

!!! WARNING !!!

These mixing valves are equipped with an adjustable high temperature limit stop factory set at approximately 120°F (49°C) with an incoming hot water supply temperature of 150°F (65.5°C). If the hot water supply temperature of the job is greater than 150°F (65.5°C), the valves when turned to full HOT will deliver water in excess of 120°F (49°C) and the limit stops **MUST BE RESET BY THE INSTALLER!**

TO RESET ADJUSTABLE HIGH TEMPERATURE LIMIT STOP:

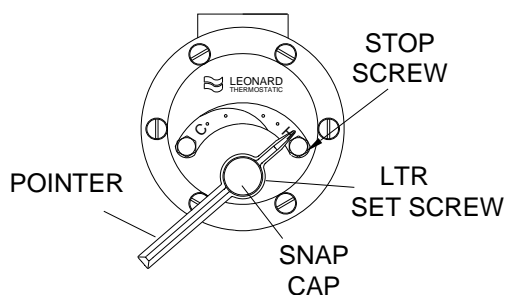

1. Loosen LTR set screw.
2. Remove SNAP CAP, SCREW & WASHER. Remove POINTER.
3. Temporarily place POINTER on the spline rod. turn RIGHT for warmer temperature, turn LEFT for cooler temperature. When valve is delivering warmest temperature desired, remove the pointer.
4. Replace POINTER on the spline rod so that its RIGHT edge is resting against the STOP SCREW located on the RIGHT SIDE OF THE COVER.
5. The new maximum temperature has now been set. Test this temperature by holding a thermometer under the flow of water to be certain it is as desired.

SEE PAGES: 6 & 7 FOR COMPLETE PARTS BREAKDOWN

Check for significant variations in outlet flow. Thermostatic valves will NOT provide the desired accuracy outside of their flow capacity range. Minimum flows must be no less than shown (see Flow Capacities, page 6).

If installed on a recirculated hot water system, make certain the valve is piped according to Leonard Required Piping (see page 3).

REMEMBER! THIS IS A CONTROL DEVICE WHICH MUST BE CLEANED AND MAINTAINED ON A REGULAR BASIS. (SEE MAINTENANCE GUIDE AND RECORD, MGR-1000).

SPECIAL PIPING METHODS

REQUIRED METHODS OF PIPING TM VALVES (RECIRCULATED HOT WATER SYSTEMS)

METHOD #1

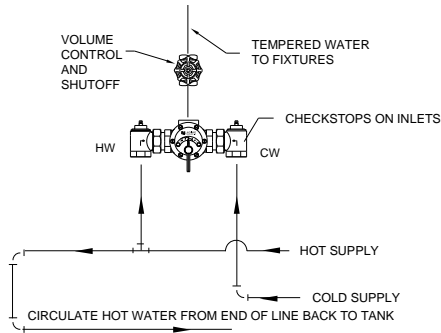

(THIS PIPING IS NOT TO BE USED FOR AN ENTIRE BUILDING!)

METHOD #1

Required when **HOT WATER** is to be circulated to a master mixer or individual thermostatic mixing valves which are a substantial distance from the hot water source. It is used primarily in a building with several risers, with tempered water in each riser controlled by a separate master mixer. NOTE: The engineer must determine maximum distance which can be run, i.e. maximum allowable time for hot water to reach user with one shower head operating, based upon code requirements and/or good practice.

METHOD #5

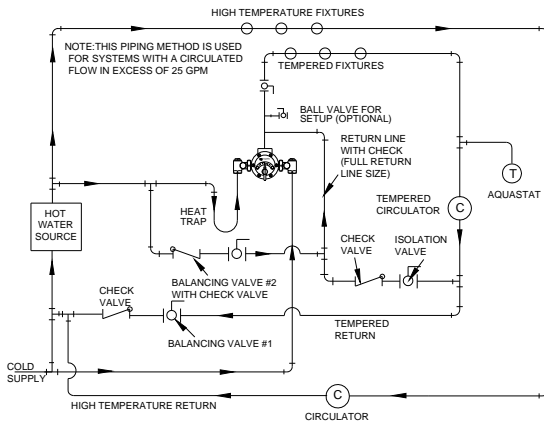

METHOD #5

Required when **TEMPERED** water is to be circulated through the entire building, to maintain tempered water at each fixture. The function of the by-pass is to allow the recirculated water to by-pass the mixing valve during periods of no draw without entering the hot water source to avoid being reheated. The ball valve allows the system to be properly balanced. The by-pass loop helps reduce the buildup of undesirable hot water in the primary system, and **MUST NOT** be omitted. See set-up instructions below.

PROCEDURE TO BALANCE CIRCULATION SYSTEM METHOD #5

1. MAKE SURE NO WATER IS BEING DRAWN IN THE BUILDING. OPEN BALANCING VALVE #1 APPROXIMATELY HALF WAY AND START CIRCULATOR. KEEP BALANCE VALVE #2 CLOSED AT THIS TIME.
2. OBSERVE TEMPERATURE UNTIL IT STABILIZES.
3. CLOSE BALANCING VALVE #1 SLIGHTLY IF TEMPERATURE IS TOO HOT, OR OPEN IT SLIGHTLY IF TEMPERATURE IS TOO COLD. ALLOW TEMPERATURE TO STABILIZE, REPEAT UNTIL DESIRED CIRCULATION TEMPERATURE IS SET.
4. IF UNABLE TO REACH DESIRED TEMPERATURE WITH VALVE #1 IN THE FULL OPEN POSITION, OPEN BALANCE VALVE #2 IN SMALL INCREMENTS (i.e. 1/8, 1/4, 3/8, ETC) UNTIL DESIRED TEMPERATURE IS ACHIEVED.

WARNING: THIS PIPING METHOD WILL NOT PERFORM EFFECTIVELY IF THE VALVE IS OVERSIZED. MINIMUM FLOWS ARE SHOWN ON FLOW CAPACITIES CHART, PAGE 6. FOR ESTIMATING MAXIMUM HOT WATER DEMAND, CONSULT LEONARD CASPAK SIZING PROGRAM.

DO NOT CONFUSE THE MINIMUM FLOW REQUIREMENTS OF THE MIXING VALVE WITH PROPER SIZING OF THE CIRCULATOR.

INSTRUCTIONS FOR SERVICING TM VALVES

1. Loosen LTR set screw
2. Remove snap cap, screw and washer, friction spring and pointer. Shut off hot and cold supplies to this valve.
3. Remove cover, screws and cover, to which the thermostat group is attached.

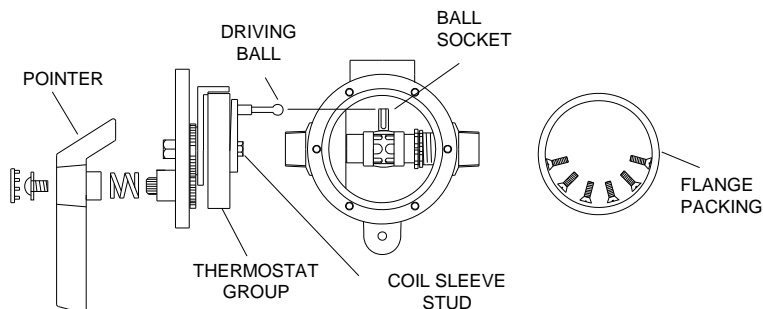

4. To clean port sleeve assembly (the thimble must slide freely on the port sleeve): unscrew the check nut as far as it will go, then screw the port sleeve nut into the base. The port sleeve and thimble may then be lifted out.
5. To clean thermostat group, remove coil sleeve stud and take off thermostat group.
6. Clean in a non-corrosive cleaning solution.
7. When reassembling, make sure driving ball of thermostat group engages the ball socket of the port sleeve assembly.

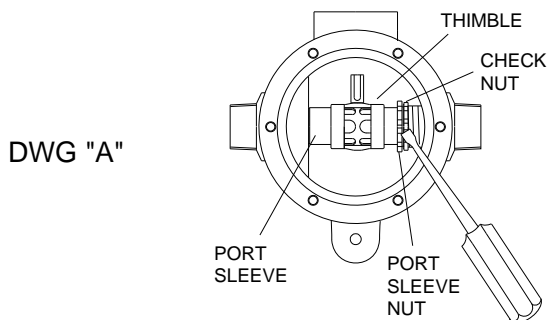

TROUBLESHOOTING INSTRUCTIONS

Note: Provide valve serial number when ordering parts for either valve!

		TM 200	TMS 200
PACKING & GASKETS	<ol style="list-style-type: none"> 1. Leaks at stem. 2. Leak between valve cover and base. 	Kit # 1/200/C	NONE
PORT SLEEVE ASSEMBLY	<ol style="list-style-type: none"> 3. Valve delivers either all hot or all cold water, or will not mix consistently. 	Kit # R/200/N	Kit # R/200/ST
THERMOSTAT GROUP	<ol style="list-style-type: none"> 4. After cleaning or replacing port sleeve assembly, valve performance is not consistent. 	Kit # R/200/N	Kit # R/200/ST
CHECKSTOPS	<ol style="list-style-type: none"> 5. Hot water by-pass into cold line (or cold into hot). 6. Supplies cannot be shut off completely. Supplies leak at checkstop bonnets. 	Kit #2/200/C	NONE

TM-200 VALVE PARTS

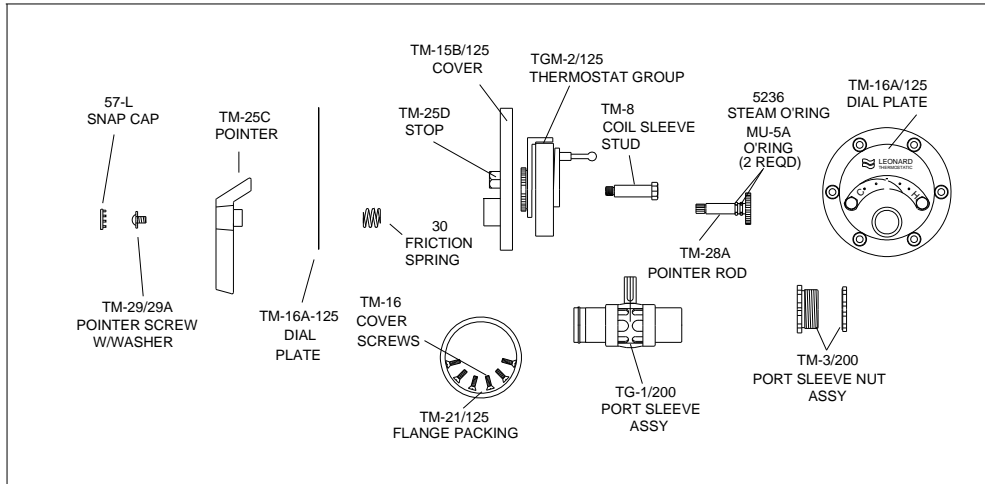

CHECKSTOP PARTS

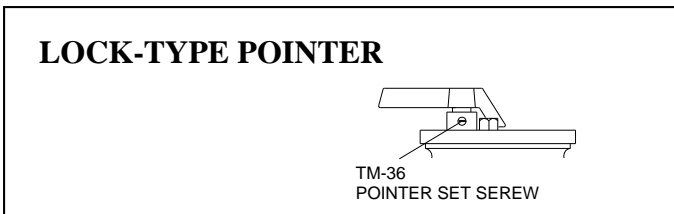
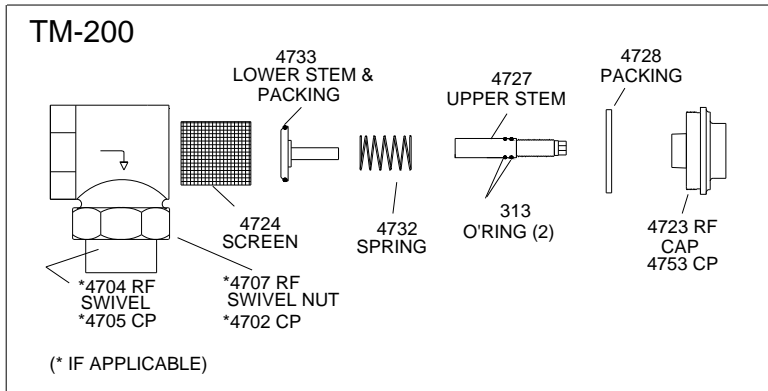

REMEMBER! THIS IS A CONTROL DEVICE WHICH MUST BE CLEANED AND MAINTAINED ON A REGULAR BASIS (SEE MAINTENANCE GUIDE AND RECORD)

NOTE: AFTER INSTALLING NEW PARTS IT WILL BE NECESSARY TO RESET THE ADJUSTABLE HIGH TEMPERATURE LIMIT STOP ON EACH VALVE (SEE PAGE 2).

REPAIR KITS

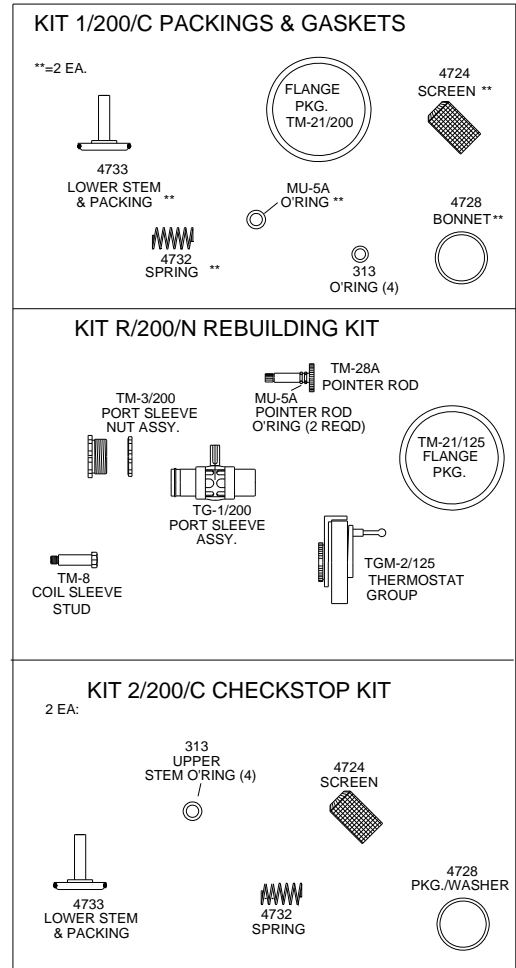

TMS-200 VALVE PARTS

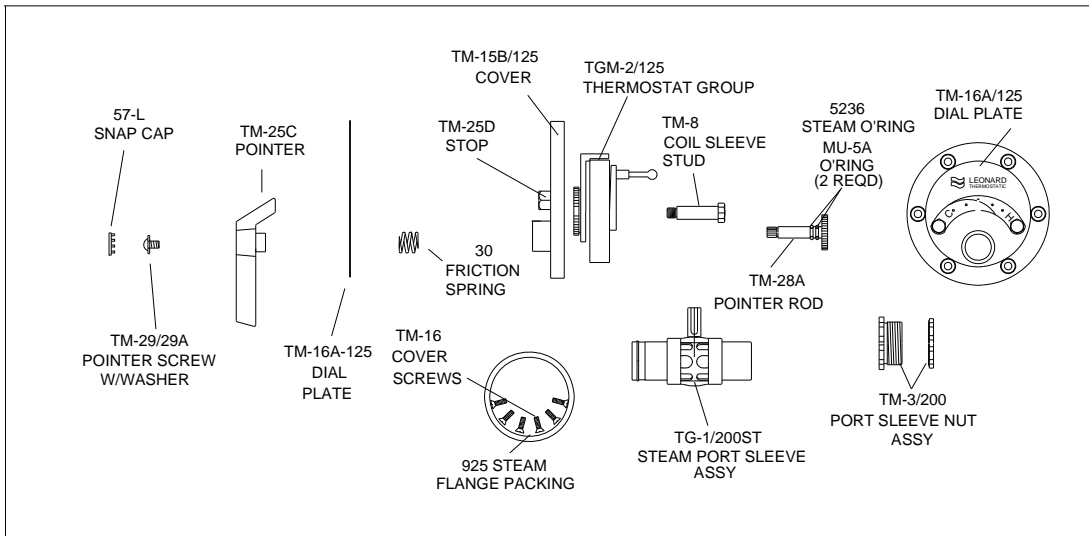

REPAIR KITS

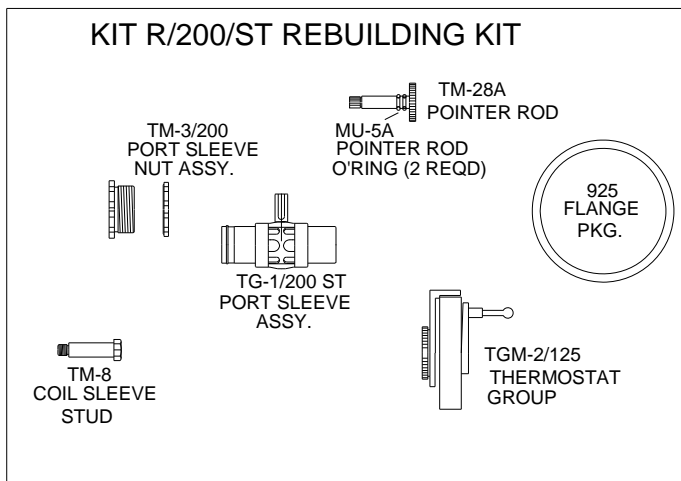

REMEMBER! THIS IS A CONTROL DEVICE WHICH MUST BE CLEANED AND MAINTAINED ON A REGULAR BASIS (SEE MAINTENANCE GUIDE AND RECORD)

NOTE: AFTER INSTALLING NEW PARTS IT WILL BE NECESSARY TO RESET THE ADJUSTABLE HIGH TEMPERATURE LIMIT STOP ON EACH VALVE (SEE PAGE 2).

FLOW CAPACITIES

MODEL	IN	OUT	MINIMUM FLOW (GPM) L/MIN	SYSTEM PRESSURE DROP										PSI BAR
				5 .3	10 .7	15 1.0	20 1.4	25 1.7	30 2.1	35 2.4	40 2.8	45 3.1		
TM-200	2"	2"	30	90	120	140	155	170	180	190	195	200	GPM	
	50.8mm	50.8mm	114	341	454	530	587	644	681	719	738	757	L/MIN	

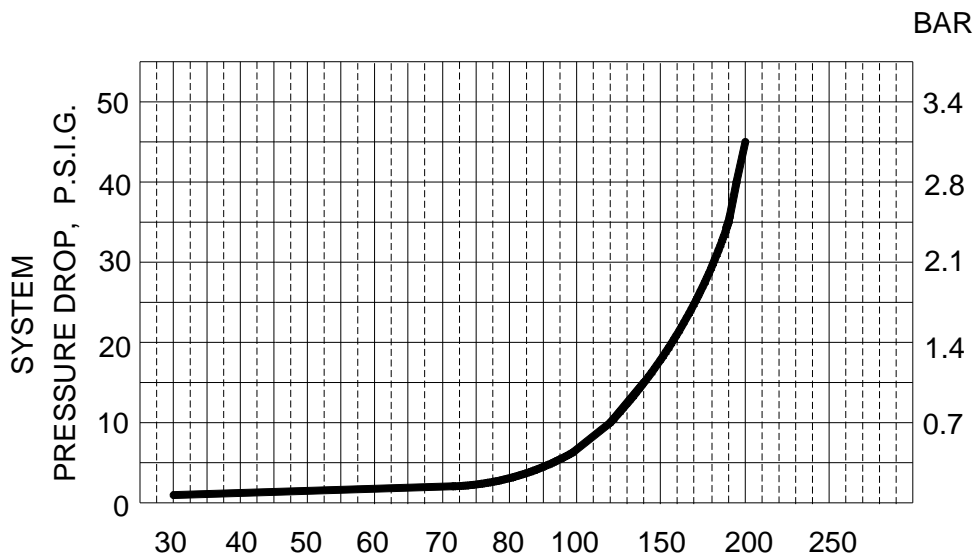

CAUTION! ALL THERMOSTATIC WATER MIXING VALVES AND SYSTEMS HAVE LIMITATIONS! THEY WILL NOT PROVIDE THE DESIRED PERFORMANCE OUTSIDE OF THEIR FLOW CAPACITY RANGE! CONSULT THE CAPACITY CHART BELOW AND OBSERVE MINIMUM FLOWS SHOWN.

LIMITED WARRANTY

Leonard Valve Company (hereinafter, "Leonard") warrants the original purchaser that products manufactured by Leonard will be free from defects in material or workmanship under normal conditions of use, when properly installed and maintained in accordance with Leonard's instructions, for a period of one year from the date of shipment. During this period, Leonard will at its option repair or replace any product, or part thereof, which shall be returned, freight prepaid, to the Leonard factory and determined by Leonard to be defective in materials or workmanship. Leonard provides no warranty, express or implied, which extends beyond the description contained herein. LEONARD SPECIFICALLY DISCLAIMS ANY AND ALL IMPLIED WARRANTIES OF MERCHANTABILITY OR OF FITNESS FOR A PARTICULAR PURPOSE. Nonetheless, some jurisdictions may not allow the disclaimer of certain implied warranties, in which case Leonard hereby limits such implied warranties to the duration of the limited warranty period contained herein. Some jurisdictions may not allow limitations on how long an implied warranty lasts, so the foregoing durational limitation may not apply to you. In no event will Leonard be liable for labor or incidental or consequential damages. Any alteration or improper installation or use of this product will void this limited warranty. If any provision of this limited warranty is prohibited by law in the applicable jurisdiction, such provision shall be null and void, but the remainder of this limited warranty shall continue in full force and effect.

7

1360 Elmwood Avenue, Cranston, RI 02910 USA

Phone: 401.461.1200 Fax: 401.941.5310

Email: info@leonardvalve.com

Web Site: <http://www.leonardvalve.com>